

# SABRE AIRCRAFT TOOLS

## SMC500 Precision Microstop Cage

- Full ball bearing design
- 0.0004" (0.01 mm) increment adjustment
- 0.551" (14.0 mm) stroke

Part No.	Cutter Thread	Skirt 30mm	Skirt 35mm	Skirt 45mm
S30501	3/8"-24	✓		
S30502	3/8"-24		✓	
S30503	3/8"-24			✓
S30504	7/16"-20	✓		
S30505	7/16"-20		✓	
S30506	7/16"-20			✓
S30507	M8X1	✓		
S30508	M8X1		✓	
S30509	M8X1			✓
S30510	M10X1	✓		
S30511	M10X1		✓	
S30512	M10X1			✓



Skirt  
45mm

Skirt  
35mm

Skirt  
30mm

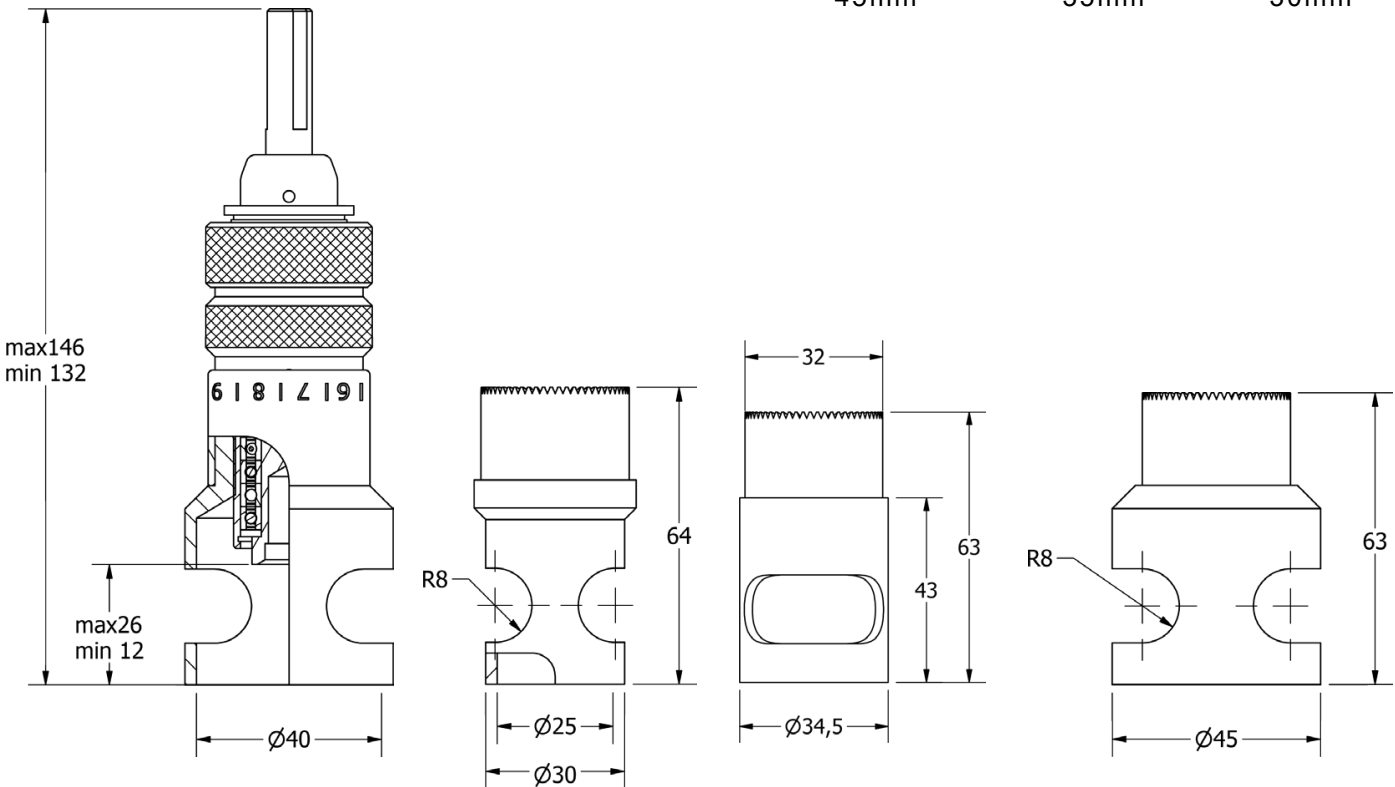

**Safety Precaution:** Read and follow all safety and operating instructions.

**WARNING:** Face and eye protections must be worn while operating power tools, per ANSI B186.1

Products and specifications subject to change without prior notice.

[www.sabretools.com](http://www.sabretools.com) • [info@sabretools.com](mailto:info@sabretools.com)

